

Rail Delivery Group



Ticket Issuing System Accreditation Guide

**Subject Ref: RSPA2000
Version: P-02-05**

Documentation Management

This documentation is published via the ASSIST website only.

The Version Control and Release Management of this documentation is managed by the Rail Delivery Group's Compliance Standards team.

Copyright

The copyright in this work is vested in Rail Settlement Plan Limited and the information contained herein is confidential. This work (either in whole or in part) must not be modified, reproduced, disclosed or disseminated to others or used for purposes other than that for which it is supplied, without the prior written permission of Rail Settlement Plan Limited. If this work or any part hereof is furnished to a third party by virtue of a contract with that party, use of this work by such party shall be governed by the express contractual terms between Rail Settlement Plan Limited which is a party to that contract and the said party. © 2023

Version History

Version	Comments
P-02-05	'Pilot' phase clarifications. Update RDG's registered/postal address. Minor updates.

Contents

1.	Introduction	6
1.1	Our role	6
1.2	Purpose of this guide	6
1.3	Intended audience	6
1.4	TIS definition	6
2.	Accreditation overview.....	7
2.1	Background	7
2.2	RDG Standards.....	7
2.3	Scope of Accreditation	7
2.4	Certification model	8
2.5	Timescales	8
3.	Ticket issuing business process.....	9
3.1	Introduction	9
3.2	Accreditation requirements	10
4.	Accreditation process	11
4.1	Overview	11
4.2	Initial discussion	14
4.3	Develop TIS	16
4.4	Application.....	17
4.5	Schedule accreditation.....	19
4.6	Compliance Review	21
4.7	Accreditation testing.....	23
4.8	Pilot	26
4.9	Certification	29
4.10	Withdraw Accreditation	30
4.11	Expire Accreditation	32
5.	Systems used by RDG accreditation	33
5.1	ASSIST	33
5.2	JIRA	33
6.	Costs	35
6.1	Accreditation charges	35
6.2	Pilot monitoring	35
6.3	Connectivity.....	35
Appendix A. JIRA categorisation		36
Appendix B. Product Record state transition diagram.....		37
Appendix C. Accreditation process checklist		38
Appendix D. Document Revision History.....		39

Terms and Definitions

Term	Meaning
ALTS	Automated Lennon Test Service: system used for the submission and verification of test SDCI+ data files. All RDG Accreditation settlement evidence is sent to ALTS, prior to entering the pilot stage.
ASSIST	Accreditation Standards Site Integrating System Toolset; RDG's Accreditation and Compliance Standards website.
CTR	Customer Transaction Record: an entry in the ToD database containing details of a customer's transaction, i.e., booked ticket(s), to enable later printing.
DTD	Data Transformation and Distribution; service providing fares, timetable and routeing data.
eTVD	Electronic Ticket Validation Database; stores barcode ticket events.
Flow	Defines the passenger journey through the combination of Origin, Destination and Route.
Interavailable	Products which are valid on the services of more than one train operator.
Interoperable	A description of the successful communications between the various RDG systems and Ticket Issuing Systems for sale, issue and settlement. For example, national Ticket on Departure and ITSO smart media schemes.
ITSO	Specification for interoperable smart ticketing schemes, owned by ITSO Ltd.
JIRA	The Issue Management portal used by RDG Accreditation.
Knowledgebase	Industry store of retail information and guides issued by National Rail Enquiries.
Lennon	Latest Earnings Networked Nationally Over Night. The financial settlements system for train operating companies.
LSM	Live Sales Management: system used to manage the CTR database.
NLC	National Location Code, a four digit code assigned to every retailing location and railway station in Britain.
PMS	Product Management System: industry system to manage fares data for all train operators.
RCS	Retail Control Service: RDG system for controlling which retailer(s) may retail a particular product and its permitted fulfilment options.
Reservation Service	Industry system to manage seat and berth reservations for all trains.
RSP	Rail Settlement Plan; now under the RDG brand providing a wide range of services to the UK's franchised passenger rail operators and third-party providers of information and retail services.
SDCI+	Standard Data Capture Interface +. The batch file interface definition for Lennon.
TIS	Ticket Issuing System; a system which provides the facility for an Authority to Travel to be selected, purchased and/or issued to a customer.
TOC	Train Operating Company; a business operating passenger trains on the UK railway network.
ToD	Ticket on Departure; a national scheme for the deferred collection of a paid-for rail product using the centralised ToD database, LSM.
TMS	Ticket Management System. RDG system and portal for the management of rail products fulfilled to smart media using ITSO.
TSA	Ticketing & Settlement Agreement; defines the obligations of TOCs and retailers, issued following privatisation.
UAT	User Acceptance Testing; testing phase undertaken to establish whether or not the requirements of the specification have been met by the completed software.

1. Introduction

1.1 Our role

- 1.1.1 The Rail Delivery Group (RDG) is responsible for the accreditation of Ticket Issuing Systems (TIS).
- 1.1.2 RDG Accreditation is the service which facilitates this and provides the following assurances to the TOCs, customers and TIS suppliers:
- a) Ensures passengers are able to purchase valid interoperable and interavailable tickets to travel, based on accurate timetable and fares data.
 - b) Ensures accurate apportionment of revenue between the TOCs.
 - c) Protects RDG systems.
 - d) Supports TIS suppliers to meet industry standards when developing their systems.

1.2 Purpose of this guide

- 1.2.1 This guide acts as an introduction to RDG Accreditation and describes its procedures as well as its scope.
- 1.2.2 It directs the reader to more detailed specification documents that cover the finer details of TIS processes and their accreditation requirements, as well as other relevant material.
- 1.2.3 This document describes the processes that must be followed to achieve accreditation.

1.3 Intended audience

- 1.3.1 This document is primarily aimed at TIS Suppliers, both existing and new, who need to understand the accreditation process in order to:
- a) Design aspects of TIS that are subject to accreditation; and
 - b) Gain system accreditation.
- 1.3.2 Retailers seeking to procure a TIS (including the TOCs) also need to understand accreditation and their role in the process in order to engage with a TIS Supplier. Information about how to become a retailer, licence conditions, obligations and so on is available on request from the RDG Commercial team at enquiries@raildeliverygroup.com.
- 1.3.3 This document is also for use by existing retailers (including the TOCs) who already operate TIS, who must keep abreast of updated accreditation processes and requirements, or who wish to extend the scope of their TIS functionality.
- 1.3.4 Generally, this document is aimed at readers with existing knowledge of transport retailing, but who may not be familiar with the details of the UK rail industry.

1.4 TIS definition

- 1.4.1 A TOC or third-party retailer will procure a TIS to carry out the retailing of industry rail products.
- 1.4.2 A TIS comprises the physical ticket issuing machine and consumables, plus any non-ticket issuing equipment, software and communication systems.
- 1.4.3 With smart ticketing methods, a TIS may include, or hand-off to, a third-party fulfilment service for the completion of a rail product.
- 1.4.4 In summary, a TIS provides the facility for an Authority to Travel to be selected, purchased and/or issued to a customer.

2. Accreditation overview

2.1 Background

2.1.1 TOCs and third-party retailers are bound by the TSA, either directly or via their retail licence, to use an 'approved' TIS that complies with the criteria specified by RDG to retail industry rail products.

2.2 RDG Standards

2.2.1 The criteria to be an 'approved' TIS is defined in the RDG Standards.

2.2.2 Conformance to the RDG Standards ensures that:

- A customer is provided with an Authority to Travel which is consistent in appearance and, accepted by all TOCs, thereby supporting interavailable travel across all passenger services in line with the TSA.
- Associated transaction data is generated in an acceptable form for interpretation by the centralised RDG settlement systems, to ensure accuracy and integrity of settlement between operators.
- Interoperable functionality between TIS is supported for reservations, ToD, and other systems.
- Fraudulent activity may be more easily identified by a retailer or operator.
- Acceptable levels of security and integrity in relation to RDG systems are maintained; and
- Disaster recovery and business continuity is supported, with robust error handling and a full audit trail.

2.2.3 RDG publishes several different types of documents, known as 'Subjects', to describe the processes and technical requirements for TIS Suppliers to become compliant with.

2.2.4 These 'Subjects' provide background, guidance and requirements on TIS design, accreditation and operation. Other relevant documents may be of either, or mixed content.

2.2.5 RDG Standards are updated from time to time, with new RDG Standards also issued.

2.2.6 Published RDG documents are accessible from ASSIST.

2.2.7 In order to allow sufficient time to react to updated RDG Standards, TIS Suppliers are generally given 6-12 months (depending on the complexity of the change) to implement the changes. In some cases, it is necessary for all TIS Suppliers to implement a change at the same time, and in such circumstances, TIS Suppliers will be given sufficient notice of such changes by RDG, who may also play a co-ordinating role.

2.2.8 It is for the TIS Supplier to determine how to design and build their TIS such that it conforms to the requirements set by RDG.

2.3 Scope of Accreditation

2.3.1 Accreditation is the verification of a TIS's functional compliance with an agreed set of versioned RDG Standards, resulting in the award of an accredited or 'approved' status to a specific version of the TIS.

2.3.2 Reaccreditation is necessary to ensure a previously 'approved' TIS remains compliant where a new version is to be released or where there are revised/new RDG Standards in effect.

2.3.3 RDG Accreditation determines if reaccreditation is necessary for a new TIS version through an assessment of the enhancements contained within the release; RDG must therefore be notified of all new TIS versions as soon as possible to avoid delay.

2.3.4 Where certain core Standards are updated by RDG following internal and external reviews, TIS Suppliers are obliged to adopt updated versions at their own cost to remain accredited.

- 2.3.5 It is the responsibility of each TIS Supplier to ensure that they have adequate financial and human resources in order to maintain their accreditation status in line with updated or newly applicable RDG Standards and specifications, which may be issued from time to time.
- 2.3.6 Where multiple TIS are involved in the end-to-end retailing solution, interrogation of a specific version of all component TISs is necessary to demonstrate collective compliance with RDG Standards.

2.4 Certification model

- 2.4.1 Accredited status is awarded to a named TIS version following completion of the accreditation process.
- 2.4.2 RDG Accreditation recognises two types of accreditation; 'full' and 'interim', as defined below. The same accreditation process is applied to each.
- 2.4.3 A 'full' accreditation cycle applies to all accreditable TIS functionality, regardless of whether or not it has been accredited previously. All current versions of the applicable RDG Standards are used, except where RDG Accreditation agrees that insufficient time has elapsed to be able to become compliant with a recently published RDG Standard. Upon completion of full accreditation, a named TIS version is awarded accredited status for three years, subject to any conditions imposed by the accompanying 'Conditions of Approval' document. These conditions include the requirement on the TIS Supplier to amend the TIS as necessary to comply with updates to RDG Standards within the specified timescale (usually twelve months after issue of a new version of a Standard).
- 2.4.4 Following review by TOCs in 2021, it was agreed that evidence submitted for a previous accreditation can be carried forward to a 'full' accreditation where the current version of an RDG Standard was used. It is hoped that this change will reduce the effort to complete a 'full' accreditation and incentivise earlier compliance with new versions of RDG Standards.
- 2.4.5 Provided a TIS Supplier is covered by the accredited status awarded following a full accreditation, a succeeding TIS version can be presented for an 'interim' accreditation. An 'interim' accreditation considers the changes in the new TIS version against the related RDG Standards and the general compliance of the TIS against new versions of RDG Standards, subject to the timescales permitted for compliance (usually twelve months after the issue of a new version of a Standard). Upon completion of an 'interim' accreditation, a named TIS version is awarded accredited status with the same expiry date as that of the most recent full accreditation, again subject to any conditions imposed by the accompanying 'Conditions of Approval' document.
- 2.4.6 A 'full' reaccreditation is required at least every three years to ensure compliance with current RDG Standards to obtain renewed accredited status.
- 2.4.7 A 'Conditions of Approval' document is issued for each accredited TIS version. It states the conditions for accredited status to be retained after the accreditation process has completed. These cover operational incidents (see categorisation criteria in Appendix A) and reaccreditation against any intervening updates to RDG Standards.

2.5 Timescales

- 2.5.1 The timescales for each accreditation process need to be individually planned, as the complexity and duration depends on the range of products to be offered and the fulfilment method supported. It is therefore advised to engage with RDG early on in the TIS design stage, and certainly prior to committing to a date for the TIS to be put into production.
- 2.5.2 Prospective TIS Suppliers should expect that completion of the accreditation process will take several months.
- 2.5.3 Furthermore, there may be a lead time to establish any connections required to RDG systems, or any other external systems. These will be stated in the relevant RDG Standards.

3. Ticket issuing business process

3.1 Introduction

3.1.1 To support the checking of TIS compliance with RDG Standards, the retailing journey for industry rail products is broken down into a series of TIS business processes, as summarised in Figure 1 below:

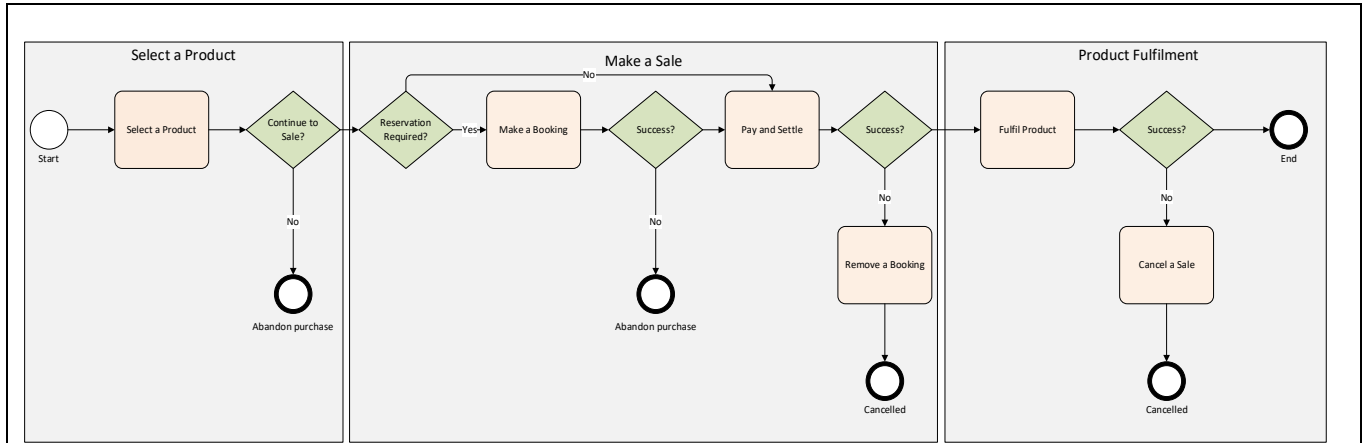

Figure 1 – TIS Business Process

- 3.1.2 'Select a Product' covers the processes of Journey Planning and Fare Only Enquiry, resulting in one or more products being selected for onward processing. At this stage no transactions are created in the TIS. Where a product is quota controlled, a Reservation Service availability check must be performed and the TIS may only allow the product to be selected if the Reservation Service shows that it has availability.
- 3.1.3 'Make a Sale' covers the process of confirming the booking of a rail product (including any reservations), taking payment from the customer, and the creation of RDG settlement data. Where a sale does not proceed, the booking is removed and any reservations are released within the maximum time period specified.
- 3.1.4 The conditions under some rail products may also permit an 'After-Sale Event' process; common examples are refunds, changeover and replacement.
- 3.1.5 Each TIS business process is described in more detail in separate RDG Standards.

3.2 Accreditation requirements

- 3.2.1 Each TIS business process comprises one or more 'Product Record' state transitions.
- 3.2.2 In this context, a product is defined by a combination of Origin, Destination, Ticket Type, Discount, Class of Travel, etc, as issued for one person (or multiple persons in the case of a group product). A TIS sales transaction can include several products, which may subsequently be refunded independently of others in the original sales transaction.
- 3.2.3 Each Product Record state transition has a set of compliance or test requirements that must be met to be accredited for that process. These are captured as accreditation requirements.
- 3.2.4 The Product Record is a logical entity and it is up to the TIS Supplier to decide how to hold it in the TIS along with a supporting audit trail which is required to meet the accreditation requirements. Conditions determine when a Product Record can move to a new state via a transition.
- 3.2.5 The lifecycle of a Product Record is based on predefined states according to where it is in the end-to-end retail process. The lifecycle is rendered as the Product Record State Transition Diagram (see Appendix B).

4. Accreditation process

4.1 Overview

- 4.1.1 The accreditation process applies to a named version of a TIS.
- 4.1.2 Figures 2 and 3 are a high-level diagram highlighting the key stages that precede and follow the accreditation process.
- 4.1.3 Several activities need to have been completed before certain stages of the accreditation process can commence, and in some cases before an application for accreditation can be made. As a reminder, all activities are listed as a separate checklist in Appendix C, though not all will necessarily apply to each individual TIS.
- 4.1.4 In some circumstances, as an alternative to the above and at the discretion of RDG, a particular TIS version may meet the conditions for an alternative accreditation process, known as 'Delegated Accreditation'.

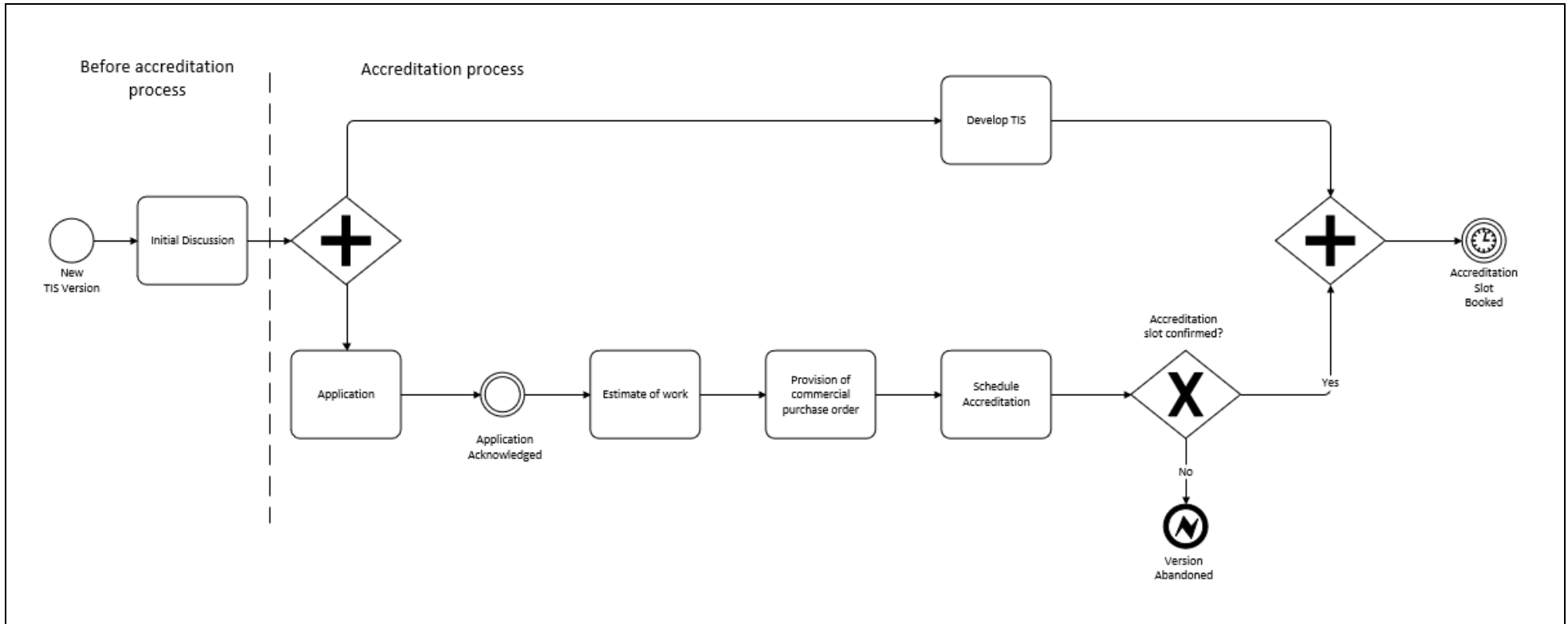

Figure 2 – Accreditation Process (Part 1)

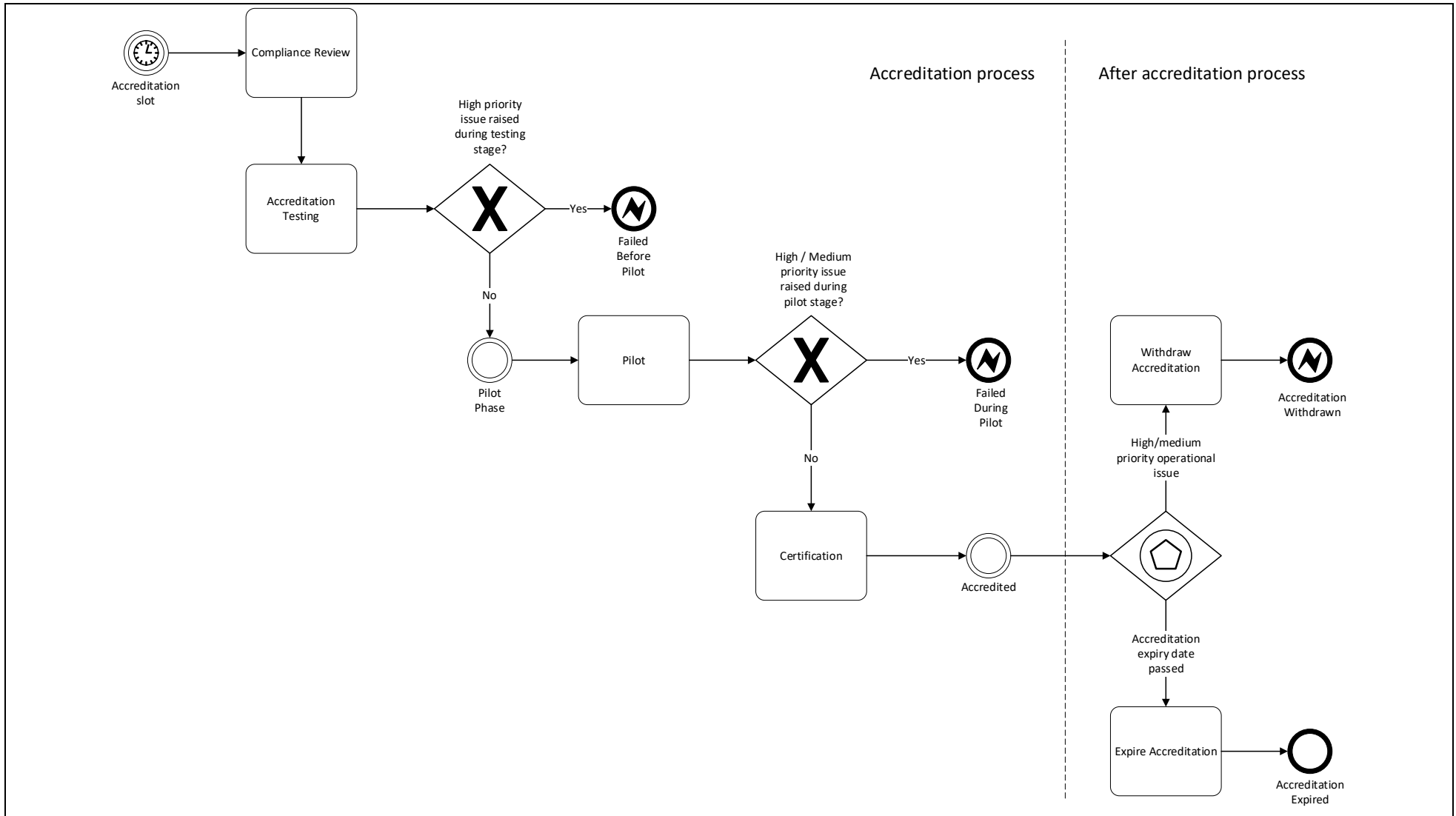

Figure 3 – Accreditation Process (Part 2)

4.2 Initial discussion

4.2.1 The 'Initial Discussion' stage is an early opportunity for the RDG Accreditation team to understand what a TIS Supplier is seeking to achieve through the implementation of a new TIS or new version of an existing TIS and identify issues that would prevent the completion of the accreditation process.

4.2.2 It may be that a new TIS feature is not supported by existing RDG Subjects and therefore cannot be accredited. Such features may align with the rail industry's retail strategy and therefore be a suitable candidate to follow the RDG innovation process, or they may not and be rejected as a result. To make this assessment, the TIS Supplier is required to provide a high-level summary of the new features to RDG, described here as a system proposal.

4.2.3 Narrative:

1. If the new TIS version is an enhancement to an existing TIS and the changes are covered by RDG Subjects, then the TIS Supplier can proceed to the application stage of the accreditation process. Otherwise, a system proposal must be sent to RDG for review.
2. The TIS Supplier provides RDG Accreditation with a system proposal describing the TIS, or new features of the TIS, at a high level. The initial contact point with RDG Accreditation is TIS.Accreditation@raildeliverygroup.com.
3. The system proposal is reviewed by RDG, in respect of existing RDG Subjects and the rail industry's current retail strategy.
4. The review will result in one of three outcomes.
 - 4.1 RDG applies the RDG Innovation Process to the system proposal.
 - 4.2 The system proposal is approved by RDG and the accreditation process can be completed as normal. The system and company is set up in ASSIST and JIRA as required. In addition, a Cat-1 JIRA Issue is raised as a reminder to that a retail licence must be in place prior to pilot entry.
 - 4.3 The system proposal is rejected by RDG and an explanation is provided to the TIS Supplier.

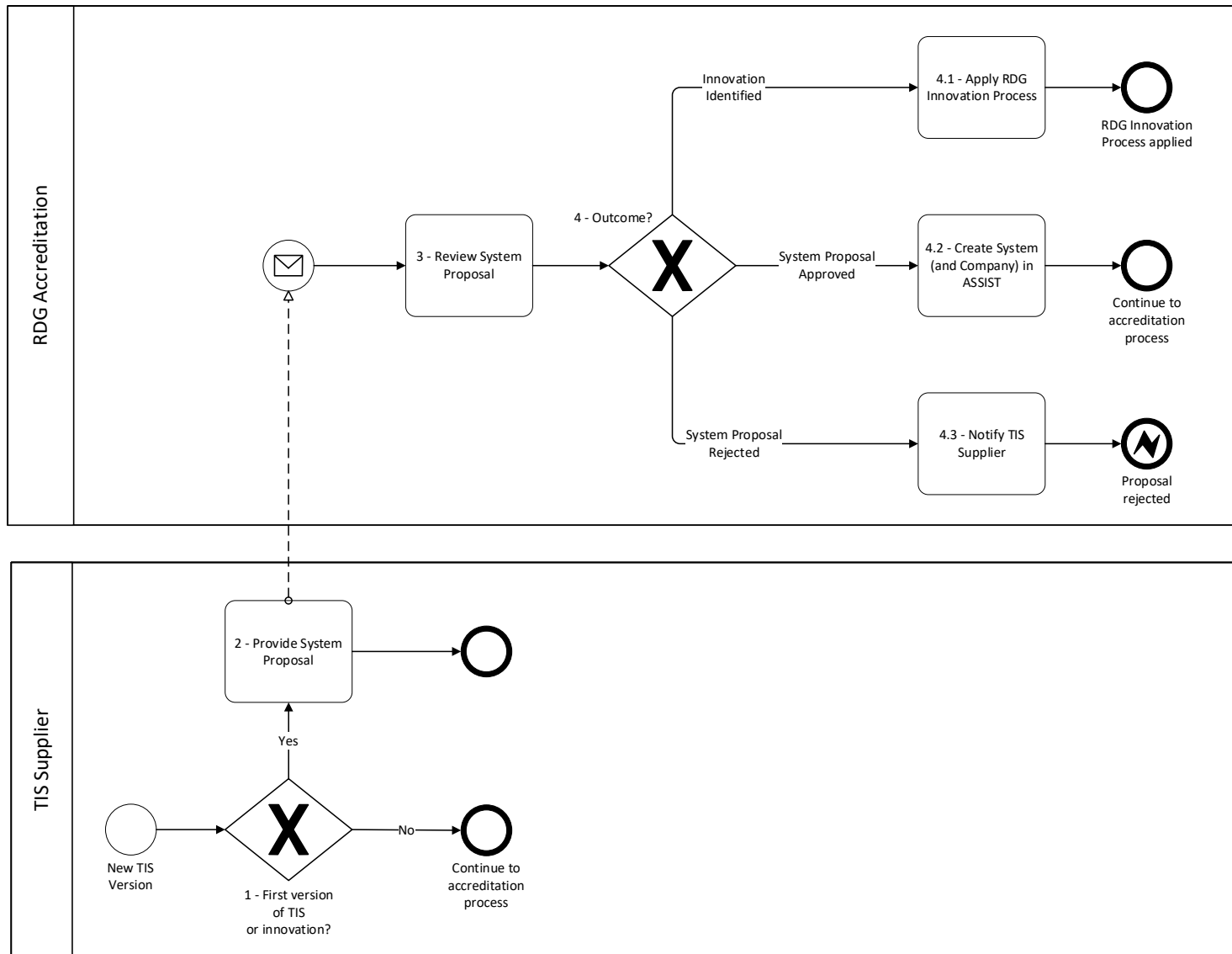

Figure 4 – Initial Discussion Process Diagram

4.3 Develop TIS

- 4.3.1 TIS Suppliers are advised to refrain from commencing TIS development in earnest until the Initial Discussion stage has completed. This is to avoid issues arising where the system proposal needs to be revised.
- 4.3.2 The TIS must be developed in accordance with the applicable RDG Standards.
- 4.3.3 Although RDG Accreditation is unable to advise on system development, support may be offered in the understanding of RDG Standards (if resourcing capability exists). Any such work is chargeable.
- 4.3.4 The TIS Supplier must request access to the relevant RDG systems. Access is initially limited to test instances of these systems, where they exist. Credentials for the equivalent live systems are provided later in the accreditation process, shortly before entry into pilot operation.
- 4.3.5 Setting up a connection to an RDG system may incur a charge or a lead time, which will be stated in the relevant RDG Standard.
- 4.3.6 All TIS development must have been completed prior to the Accreditation Testing stage to ensure the legitimacy of accreditation checks.

4.4 Application

- 4.4.1 RDG Accreditation requires the technical details of a TIS version to estimate the accreditation effort involved and define the scope of accreditation (Compliance Review stage). This information is captured in a 'functional specification' document and is needed to make an application for accreditation.
- 4.4.2 An application should only be made when the content of the TIS version is finalised, or near to completion, to ensure accuracy of the accreditation estimate and resourcing. It is preferable to de-scope certain features of a TIS version than for functionality to be added at a late stage.
- 4.4.3 A functional specification document should include:
- All new functionality in the TIS version (or all functionality for a new TIS).
 - A description of the retailing and issuing processes.
 - Architecture diagram of system components, including any external APIs.
 - Any RDG Accreditation JIRA issues resolved in the TIS version.
 - Any changes made to achieve compliance with updated RDG Standards.
 - The previous version of the TIS to which the new version is based on; and
 - The envisioned deployment dates.
- 4.4.4 If the functional specification document does not adequately explain the behaviour of the TIS, the Compliance Review stage of the accreditation process will be unnecessarily prolonged.
- 4.4.5 An application must be made for all versions of a TIS, so that it is recorded in ASSIST. RDG Accreditation will determine whether a version is subject to accreditation or not, based on the application. Any decision not to perform accreditation of a TIS version needs to be recorded for audit purposes.
- 4.4.6 Narrative:
1. The TIS Supplier produces a functional specification document for the TIS version.
 2. The TIS Supplier makes an application for accreditation of a new TIS version in ASSIST, setting properties that are applicable to the TIS version and attaching the functional specification document.
 3. RDG Accreditation informs central RDG system providers of the new TIS version and creates a record in RDG Accreditation's issue management tool, JIRA.

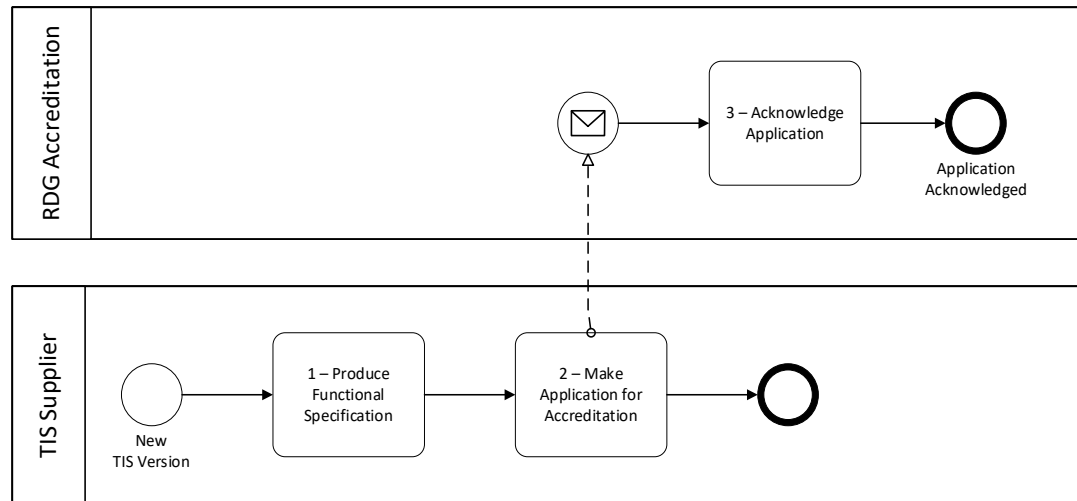

Figure 5 – Application Process Diagram

4.5 Schedule accreditation

- 4.5.1 From the content of the application and associated functional specification, RDG Accreditation can estimate the accreditation effort involved and provisionally confirm a slot for accreditation of the TIS version.
- 4.5.2 An accreditation slot is formalised when a purchase order is received from the TIS Supplier for the estimate of accreditation effort. The exception is where a supplier has an accreditation contract (see section 6) and intends to use their contracted amount of accreditation resource.
- 4.5.3 RDG Accreditation will only invoice for work carried out, which may be different from that specified in the estimate.
- 4.5.4 On rare occasions, for small changes to a TIS, RDG may determine that no accreditation is required. The new TIS version will take the same status as the previous version, which may be unaccredited.
- 4.5.5 Narrative:
1. The TIS Supplier application, including the functional specification document, is reviewed by the RDG Accreditation team to determine the amount of accreditation effort required.
 2. RDG Accreditation checks whether the accreditation effort can be absorbed by an existing accreditation contract with the TIS Supplier.
 - 2.1 If the application is not covered by an existing accreditation contract with the TIS Supplier, the RDG Accreditation Business Manager provides the supplier with the estimate of accreditation effort.
 - 2.1.1 If the TIS Supplier declines to raise a purchase order for the accreditation effort estimated the status of the TIS version is changed to 'Version Abandoned'.
 - 2.1.2 Alternatively, the TIS Supplier raises a purchase order for the accreditation effort estimated.
 - 2.2 If the application is covered by an existing accreditation contract with the TIS Supplier, or the TIS Supplier has raised a purchase order, the RDG Accreditation Business Manager adds accreditation of the TIS Version to the work plan and inputs the Accreditation Start Date in ASSIST [this may however be subject to change]

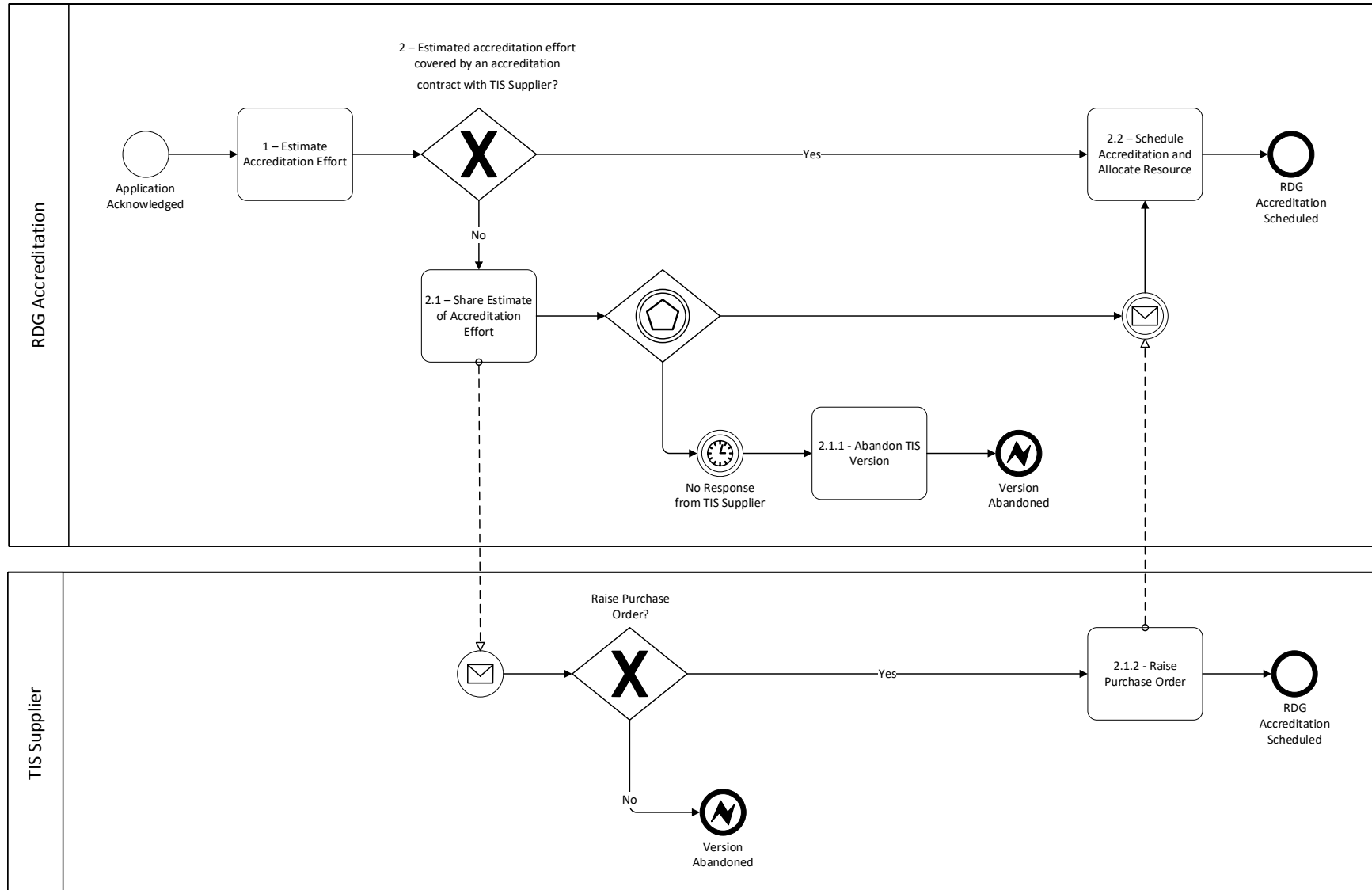

Figure 6 – Schedule Accreditation Process Diagram

4.6 Compliance Review

4.6.1 The Compliance Review stage begins when the accreditation slot arrives.

4.6.2 A 'Compliance Review' document is produced to confirm the RDG Accreditation team's understanding of the content of the new TIS version, define the scope of accreditation and set the testing requirements to achieve accreditation.

4.6.3 The 'Compliance Review' document identifies the RDG Standards to be used for the accreditation testing and the relevant version for each (generally the latest version of each Standard will apply). If a new version of an RDG Standard has only recently been published, RDG may allow the previous version of the RDG Standard to be used for the accreditation. However, the TIS Supplier must provide a plan for achieving compliance with the latest version within the timescale specified at the time of publication (usually twelve months).

4.6.4 An issued 'Compliance Review' document is valid for three months and must be revisited should the accreditation testing not have completed in this time to review whether more recent versions of RDG Standards should be used instead.

4.6.5 For a small change to an existing TIS version (e.g., fault fix), then RDG Accreditation team may not require a Compliance Review document to be written.

4.6.6 Narrative:

1. The RDG Accreditation Analyst creates a draft Compliance Review document based on the information provided by the TIS Supplier during the Application stage. It is then shared with the TIS Supplier.
2. The draft Compliance Review document is reviewed by the TIS Supplier, who may raise comments of their own.
3. The RDG Accreditation Analyst addresses any comments raised by the TIS Supplier and obtains their agreement to formally issue the document.
4. The Compliance Review document is formally issued by the RDG Accreditation Analyst.

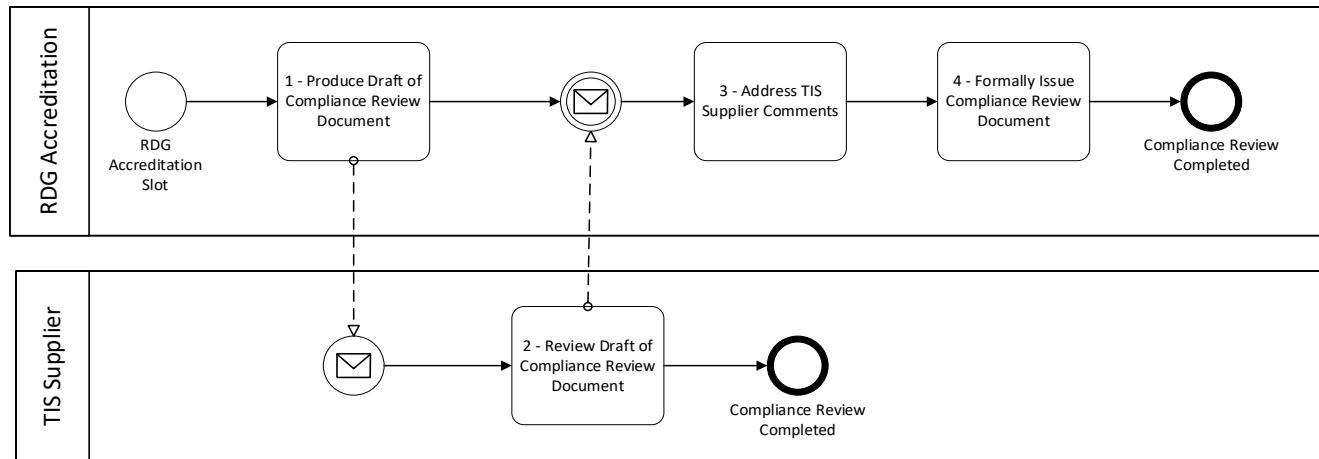

Figure 7 – Compliance Review Process Diagram

4.7 Accreditation testing

- 4.7.1 The agreed test coverage set out in the issued 'Compliance Review' document is completed against the agreed versions of RDG Standards.
- 4.7.2 RDG Accreditation recommends that UAT is concluded before entry into this stage to avoid the need for repetition of accreditation activities.
- 4.7.3 There may be (up to) four elements of accreditation testing.
- Fixes to RDG Accreditation JIRA issues.
 - Accreditation Requirements in RDG Standards.
 - Test Library scenarios.
 - Regression testing, including interoperability testing.
- 4.7.4 Demonstration of compliance with an accreditation requirement from an RDG Standard may take several forms:
- A written statement of compliance.
 - A screenshot or visual evidence provided.
 - Physical evidence provided.
 - Witness testing with RDG Accreditation.
- 4.7.5 Test results from UAT or regression testing can be presented as accreditation evidence provided there has been no subsequent change to that element of the TIS.
- 4.7.6 The TIS Supplier should present evidence in ASSIST (unless the form of evidence prevents doing so), by uploading files and providing any relevant comments or statements. Comments are of a more transient nature (e.g., discussion to clarify requirements), whereas Statements are permanent and are carried forward to any subsequent interim accreditation.
- 4.7.7 Any highlighted non-compliance is recorded in JIRA, with the severity of the issue set according to the categorisation criteria (see Appendix A). Following submission and checking of all test evidence, RDG Accreditation reviews any open JIRA issues against the TIS version. Any unresolved JIRA issues from previous TIS versions are associated with the new TIS version and are included in the review. If there are any open Category 1 (Cat-1) issues associated with the TIS version, accreditation testing cannot be completed.
- 4.7.8 Where a TIS version has failed accreditation testing, a new system build is required to resolve the issue, resulting in a new TIS version to be presented for accreditation to track the change(s). If all test evidence has passed accreditation checks, and no Cat-1 issues are open, the TIS version is authorised to enter pilot – subject to an approved pilot plan.

4.7.9 Narrative:

1. The Accreditation Analyst assigns applicable tests from RDG Standards, the Test Library or elsewhere to the TIS Supplier.
2. The TIS Supplier carries out the tests assigned to them and submits the evidence. Test evidence may be completed and submitted to RDG in batches. This approach is preferable so that checking by RDG Accreditation can commence as soon as possible.
3. Test evidence is checked by the RDG Accreditation Analyst.
4. The outcome of the test is set by the RDG Accreditation Analyst
 - 4.1 If the test is passed, the RDG Accreditation Analyst sets the outcome to “Pass”.
 - 4.2 If the test is not passed, the RDG Accreditation Analyst raises a JIRA issue containing details of why the test was not passed.
5. The RDG Accreditation Analyst will repeat step 4 until all test evidence has been checked.
6. Once all test evidence has been checked, the RDG Accreditation Analyst reviews the open JIRA issues that apply to the TIS version.
7. The RDG Accreditation Analyst will check for open JIRA issues that are Cat-1.
 - 7.1 If there are no Cat-1 JIRA issues applicable to the TIS version, then pilot entry is authorised.
 - 7.2 If there is an open Cat-1 JIRA issue applicable to the TIS version, then accreditation testing is failed. A new TIS version is needed to track resolution of the Cat-1 issue(s).

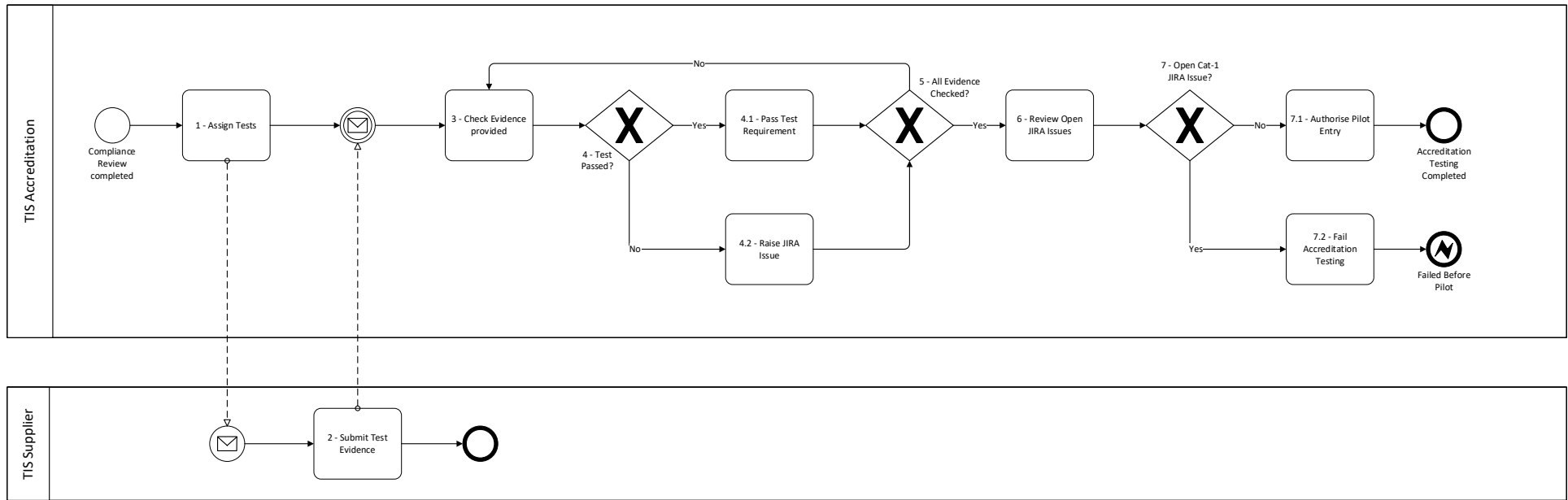

Figure 8 – Accreditation Testing Process Diagram

4.8 Pilot

- 4.8.1 The Pilot stage is a period of live operation of a TIS and all sales must be settled through RDG systems. Pilot planning is required to ensure a TIS version is deployed in a controlled manner to mitigate any risks, whilst attaining sufficient volume of traffic to prove system performance.
- 4.8.2 Pilot operation is for four weeks to include the full period-end settlement process so that the retailer can verify revenue apportionment. If a four-week pilot does not provide sufficient evidence for the correct operation of the key new features in the TIS version, a longer pilot will be required. Only in exceptional circumstances may RDG Accreditation accept a pilot of shorter duration.
- 4.8.3 RDG Accreditation will seek authorisation from the RDG Commercial team that the retailer involved in the pilot (if a Third-party) has been issued with a retail licence prior to allowing the TIS to commence pilot operation.
- 4.8.4 To ensure the availability of personnel to respond to any immediate issues, pilot cannot commence on a Friday or Saturday, or any day preceding a bank holiday in England. In addition, the pilot plan must be agreed at least 3 business days' before entering pilot.
- 4.8.5 If necessary, RDG Accreditation may closely monitor settlement records during pilot. This service introduces an additional cost to the TIS Supplier.
- 4.8.6 The piloting retailer (which may be a TOC) will be consulted during pilot and invited to comment on the TIS performance.
- 4.8.7 Any issues that occur during pilot are raised as a JIRA Issue. The severity of the issue is set according to the categorisation criteria (See Appendix A).
- 4.8.8 If any issue is determined to be Cat-1 in severity, pilot operation is suspended immediately, and the TIS must rollback to the previous version or be withdrawn from customer use. Issues outside of Cat-1 in severity do not impact continuation of the pilot.
- 4.8.9 At the end of the pilot, all open JIRA issues that apply to the TIS version are reviewed. If a Cat-2 issue remains unresolved, the system is considered to have failed during pilot. This prevents further rollout of the TIS version, and ultimately means that the retailer is in breach of their licencing obligations to use an accredited retail solution.
- 4.8.10 It may be beneficial to enter or continue pilot operation with a Cat-2 issue open so that confidence in the TIS version can be achieved in other areas. However, this TIS version will fail accreditation at the end of the pilot, and a new TIS version will need to be accredited.
- 4.8.11 Exit from pilot operation is permitted with open Cat-3 or Cat-4 JIRA issues.

4.8.12 Narrative:

1. The supplier provides RDG Accreditation with a pilot plan for TIS deployment and fills out the pilot site information in ASSIST.
2. The pilot plan is reviewed by RDG Accreditation and RDG Commercial teams (if involving a Third-Party), who may instruct changes, and an agreement is reached with the TIS Supplier. RDG will also determine whether the pilot monitoring service is required.
3. The TIS version is deployed by the supplier in accordance with the pilot plan.
4. The pilot of the TIS version is monitored and will complete as planned or be terminated early if a Cat-1 JIRA issue is raised.
 - 4.1 Where the pilot period has completed without a Cat-1 JIRA issue being raised, then the other open JIRA issues that apply are reviewed by RDG.
 - 4.2 Where a Cat-1 JIRA issue is raised during the pilot period, the pilot is aborted and the TIS version is rolled back or withdrawn from public use.
5. If pilot period is completed without a Cat-1 JIRA issue, RDG checks whether any Cat-2 JIRA issues apply to the TIS version.
 - 5.1 If no Cat-2 JIRA issues apply to the TIS version, then RDG authorises pilot exit.
 - 5.2 If a Cat-2 JIRA issue applies to the TIS version, then the pilot is marked as failed.

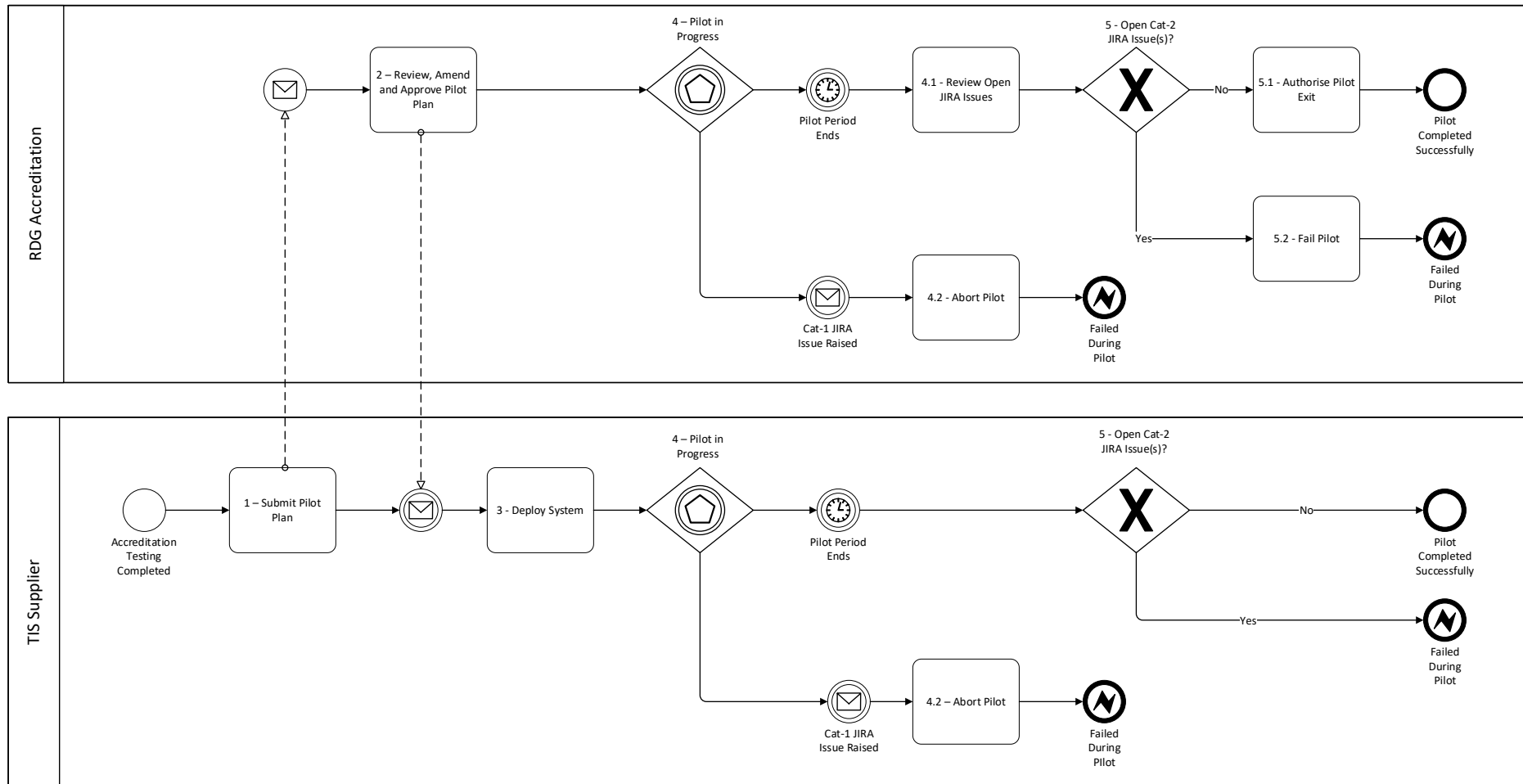

Figure 9 – Pilot Process Diagram

4.9 Certification

- 4.9.1 Following successful completion of pilot, RDG Accreditation issues a 'Conditions of Approval' document, which sets out the accredited functionality of the TIS version and the conditions for accredited status to be retained.
- 4.9.2 The 'Conditions of Approval' document states the scope of testing carried out by RDG Accreditation and against which versions of RDG Standards, including the caveat that testing only pertains to the integrity of settlement and ticketing, including the protection of RDG systems.
- 4.9.3 Schedules to the document will contain the details of concessions granted to the system.
- 4.9.4 The TIS cannot be deployed beyond the constraints set in the 'Conditions of Approval' document without seeking re-accreditation of a new version of the system.
- 4.9.5 A TIS's accredited status pertains to a specific evidence-tested version of all, accreditable, component systems that comprise the end-to-end retail solution.
- 4.9.6 The 'Conditions of Approval' document is time-constrained and accompanied by a 'Certificate of Accreditation'.
- 4.9.7 Narrative:
1. The RDG Accreditation Analyst creates a draft 'Conditions of Approval' document listing the accredited functionality for the TIS version and defining any conditions of its accredited status.
 2. The draft 'Conditions of Approval' document is reviewed by the TIS Supplier, who may raise comments of their own.
 3. The RDG Accreditation Analyst considers any comments raised by the TIS Supplier.
 4. The 'Conditions of Approval' document is formally issued by the RDG Accreditation Analyst along with a 'Certificate of Accreditation'.

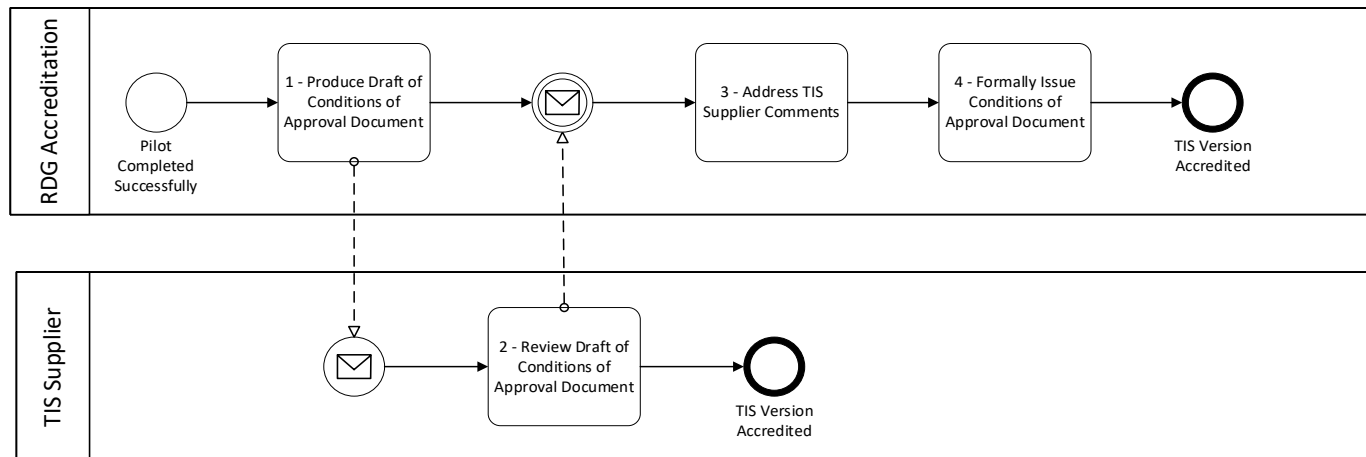

Figure 10 – Certification Process Diagram

4.10 Withdraw Accreditation

4.10.1 A TIS may have accreditation withdrawn for one of three reasons:

- 1) RDG systems and / or the RDG data feeds no longer provide for all of the TIS functionality.
- 2) The TIS has been decommissioned by the supplier.
- 3) Failure to address critical compliance issues

4.10.2 In the first case, RDG will provide the TIS supplier(s) reasonable time to upgrade their software to correct any errors or issues, or to remove the dependency on obsolete functionality.

4.10.3 In the second case of decommissioning, RDG will consult with the industry in respect of initiatives to decommission previously accredited TIS. This consultation will be driven by future business requirements and agreed strategy in respect of such accredited products. Following this consultation, RDG will identify a date by which all installations should have been decommissioned. From this date the product will be declared 'Accreditation Withdrawn'.

4.10.4 In the final case that a supplier fails to address critical compliance issues in the previously declared timescales, RDG will withdraw accreditation for the product. This withdrawal of accredited status will be accompanied with a notice to the known customer base.

4.10.5 In each case, a Cat-1/Cat-2 JIRA Issue will be raised to capture the issue and set a due date, after which the status of the TIS version will be amended in ASSIST to 'Accreditation Withdrawn'.

4.10.6 Narrative:

1. An operational issue is reviewed by RDG Accreditation to determine the due date for resolution. An RDG JIRA issue is raised, and the due date is added.
2. Following an operational RDG JIRA being raised, the outcome will be either:
 - 2.1 A further operational issue is raised, requiring step 1 to be repeated; or
 - 2.2 The due date for an open RDG JIRA passes.
3. When the due date for an RDG JIRA has passed, the status of the TIS version is moved to 'Accreditation Withdrawn'.

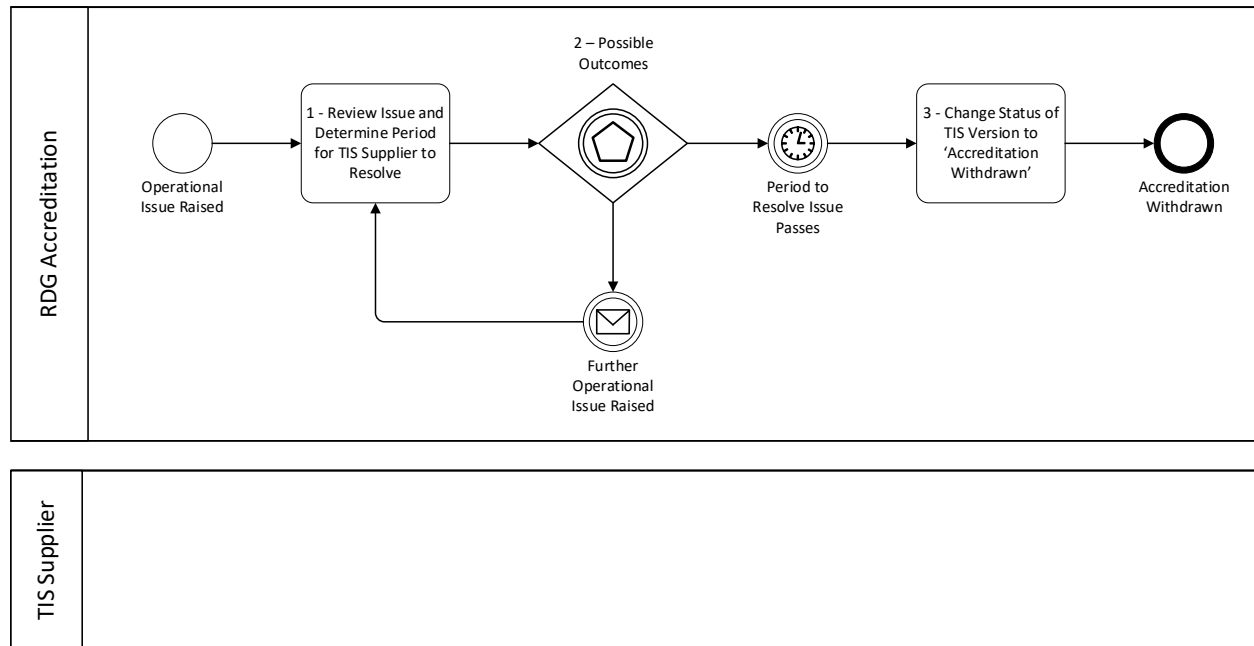

Figure 11 – Withdraw Accreditation Process Diagram

4.11 Expire Accreditation

- 4.11.1 The ‘Conditions of Approval’ document issued to a TIS version following completion of the accreditation process is time limited. When the accreditation expiry date passes, the status of the TIS version is moved to ‘Accreditation Expired’.
- 4.11.2 It is the responsibility of the TIS Supplier to complete a full accreditation and rollout of a subsequent TIS version before the accreditation expiry date of the current TIS version passes.
- 4.11.3 Narrative:
 - 1. When the accreditation expiry date of a TIS version passes, the status of the TIS version is updated by RDG to ‘Accreditation Expired’.

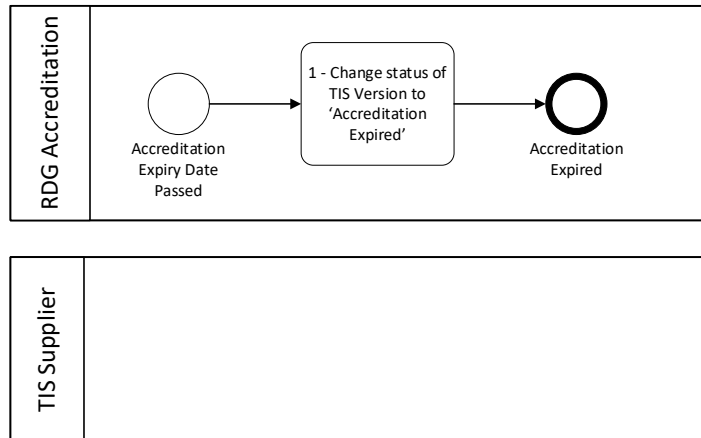

Figure 12 – Expire Accreditation Process Diagram

5. Systems used by RDG accreditation

5.1 ASSIST

- 5.1.1 ASSIST is a web portal used by the RDG Standards & RDG Accreditation teams, as well as TOCs and TIS Suppliers.
- 5.1.2 Current and previous RDG Standards are available to download from ASSIST.
- 5.1.3 The accreditation process is tracked through ASSIST.
- 5.1.4 A user's access is restricted to those areas relevant to them, to safeguard the commercially sensitive information of any other company.
- 5.1.5 A user account for ASSIST can be requested from the landing page at www.rspaccreditation.org. RDG will verify an account request with a known ASSIST user for the company.
- 5.1.6 Training and training materials for the ASSIST portal can be requested from RDG Accreditation at TIS.Accreditation@raildeliverygroup.com.

5.2 JIRA

- 5.2.1 Any issues raised during the accreditation process are logged in RDG Accreditation's issue management portal, JIRA, available at <https://raildeliverygroup.atlassian.net>.
- 5.2.2 Any issues highlighted outside of the accreditation process are also raised in JIRA but are categorised as 'operational'.
- 5.2.3 Every TIS and its associated version number is added to JIRA, so that an issue can be associated with the affected TIS version(s).
- 5.2.4 JIRA terminology uses 'Project' for a TIS, and 'Component' for a TIS version.
- 5.2.5 A request for a JIRA account should be sent to TIS.Accreditation@raildeliverygroup.com. The request must include the following information:
- Email subject of 'JIRA Account Request'.
 - Name.
 - Company.
 - Job Title.
 - List of TIS that access is requested for.
- 5.2.6 RDG Accreditation will verify the request with a known JIRA user for the company.
- 5.2.7 Access requests from TOCs can only be granted with the agreement of the TIS Supplier(s) appropriate to the Project(s) requested.
- 5.2.8 Access in JIRA is restricted to the TIS(s) for which a user has been granted permission to view.
- 5.2.9 All users can view, create, comment, add watchers and change assignee of an Issue for the TIS(s) for which they have access to.
- 5.2.10 Only RDG can amend the severity of a JIRA Issue or amend the status of an Issue to 'Closed'.

5.2.11 The severity of a JIRA Issue will be set by RDG Accreditation according to the categorisation criteria set out in Appendix A. An Issue in JIRA has the following lifecycle:

- **Open:** the first state of a JIRA Issue when it has been created.
- **In Progress:** the state when a fix to the Issue is being progressed.
- **Monitoring:** a fix to an Issue may need to be demonstrated during the pilot stage of the accreditation process and is monitored for reoccurrence.
- **Resolved:** a fix to an issue has been demonstrated and confirmed by RDG Accreditation. The TIS version containing the fix is added to the 'Fix Version' field.
- **Closed:** all TIS versions affected by the Issue have been upgraded to a new version which does not carry the same issue.
- **CoA/Compliance Review:** RDG Accreditation has determined that a fix for the Issue is not required at this time. This exception is recorded in the 'Conditions of Approval' document issued at the end of the accreditation process.

6. Costs

6.1 Accreditation charges

6.1.1 RDG Accreditation charges for time expended on accreditations on a time and expenses basis. Please contact TIS.Accreditation@raildeliverygroup.com for details of current rates.

6.1.2 A Supplier may enter into a contract with RDG Accreditation to purchase a fixed number of days' accreditation resource per rail period, at a reduced rate.

For further details contact: TIS.Accreditation@raildeliverygroup.com

6.1.3 The estimate for accreditation effort required will be based on prior experience of running the accreditation process on a range of different types of TIS. The factors affecting the effort required for accreditation include:

- Complexity of the TIS design and associated functionality (e.g., product range, fulfilment methods supported, journey planning functionality).
- Proposed scale of implementation and the likely risks to settlement.
- Information provided to RDG in the application stage of the accreditation process.
- Co-operation from the TIS Supplier during the accreditation process.
- Quality and execution of the testing carried out by the supplier prior to accreditation; and
- Quality of test evidence submitted to RDG.

6.1.4 An estimate of the likely cost of accreditation will be provided prior to the commencement of work, however any reference to dates or timescales for the completion of an activity by RDG shall be an estimate only.

6.2 Pilot monitoring

6.2.1 RDG Accreditation may require close monitoring of settlement records during the pilot stage of the accreditation process.

6.2.2 Pilot monitoring incurs a separate weekly charge to monitor a fixed number of TIS instances.

6.3 Connectivity

6.3.1 Connection to an RDG data feed or system may incur a charge. Likewise, a charge may be levied to use a third-party system involved in the retailing process.

6.3.2 The nature of the charging regime, and any lead times to connect, are provided in the relevant RDG Standard.

Appendix A. JIRA categorisation

Accreditation and Operations Issues can be categorised as one of three levels of severity, as described below. It may be necessary to temporarily place an issue in Category 4 should a resolution require assistance from a third party.

Definition	Compliance Review & Accreditation	Pilot Operation	Live Operation
Category 1	The issue has a business-critical impact on RDG Systems, RDG Services or the chosen fulfilment process, causing any one of them to stop working, or has an impact on the accuracy of settlement. There is evidence that RDG Systems, RDG Services or the chosen fulfilment process have stopped working, or that settlement is inaccurate.		
Action	Agree with the supplier how and when the issue will be fixed during accreditation and record in JIRA. This will include any re-accreditation work. The TIS cannot proceed into Pilot Operation until the issue has been closed by RDG.	The issue must be fixed within the business day. Pilot Operation must cease and the TIS regressed to the previous accredited version pending re-accreditation. RDG to escalate the issue to TIS customer(s) if the deadline to fix is missed.	The issue must be fixed within the business day and an emergency patch implemented. If unable to patch, the supplier must regress to the previous accredited version within the business day. RDG to escalate the issue to TIS customer(s) if the deadline to fix is missed.
Category 2	The issue has a non-business critical impact and whilst RDG Systems, RDG Services or the chosen fulfilment process are still able to operate, the quality or timeliness of RDG Systems, RDG Services or the chosen fulfilment process is being impacted. There is evidence that RDG Systems, RDG Services or the chosen fulfilment process are being adversely impacted. There is no impact on the accuracy of settlement.		
Action	Agree with the supplier how and when the issue will be fixed during accreditation and record in JIRA. This will include any re-accreditation work. The TIS can still enter Pilot Operation with the issue open.	Agree with the supplier how and when the issue will be fixed during Pilot Operation and record in JIRA. This will include any re-accreditation work. The TIS cannot exit Pilot Operation until the issue has been fixed. RDG to escalate the issue to TIS customer(s) if the deadline to fix is missed.	Agree with the supplier how and when the issue will be fixed and record in JIRA. This will include any re-accreditation work. RDG to escalate the issue to TIS customer(s) if the deadline to fix is missed.
Category 3	The issue does not impact on RDG Systems, RDG Services or the chosen fulfilment process. There is no evidence that RDG Systems, RDG Services or the chosen fulfilment process are being adversely impacted. There is no impact on the accuracy of settlement.		
Action	Agree with the supplier how and when the issue will be fixed and record in JIRA. The TIS can still enter Pilot Operation with the issue open.	Agree with the supplier how and when the issue will be fixed and record in JIRA. The TIS can still exit Pilot Operation with the issue open.	Agree with the supplier how and when the issue will be fixed and record in JIRA. RDG to escalate the issue to TIS customer(s) if the deadline to fix is missed.
Category 4	An issue has been identified but cannot be resolved without action by a third-party. Evidence and acknowledgement are needed from the third-party.		
Action	Monitor progress of third-party resolution and re-categorise when dependency has been removed.	Monitor progress of third-party resolution and re-categorise when dependency has been removed.	Monitor progress of third-party resolution and re-categorise when dependency has been removed.

Appendix B. Product Record state transition diagram

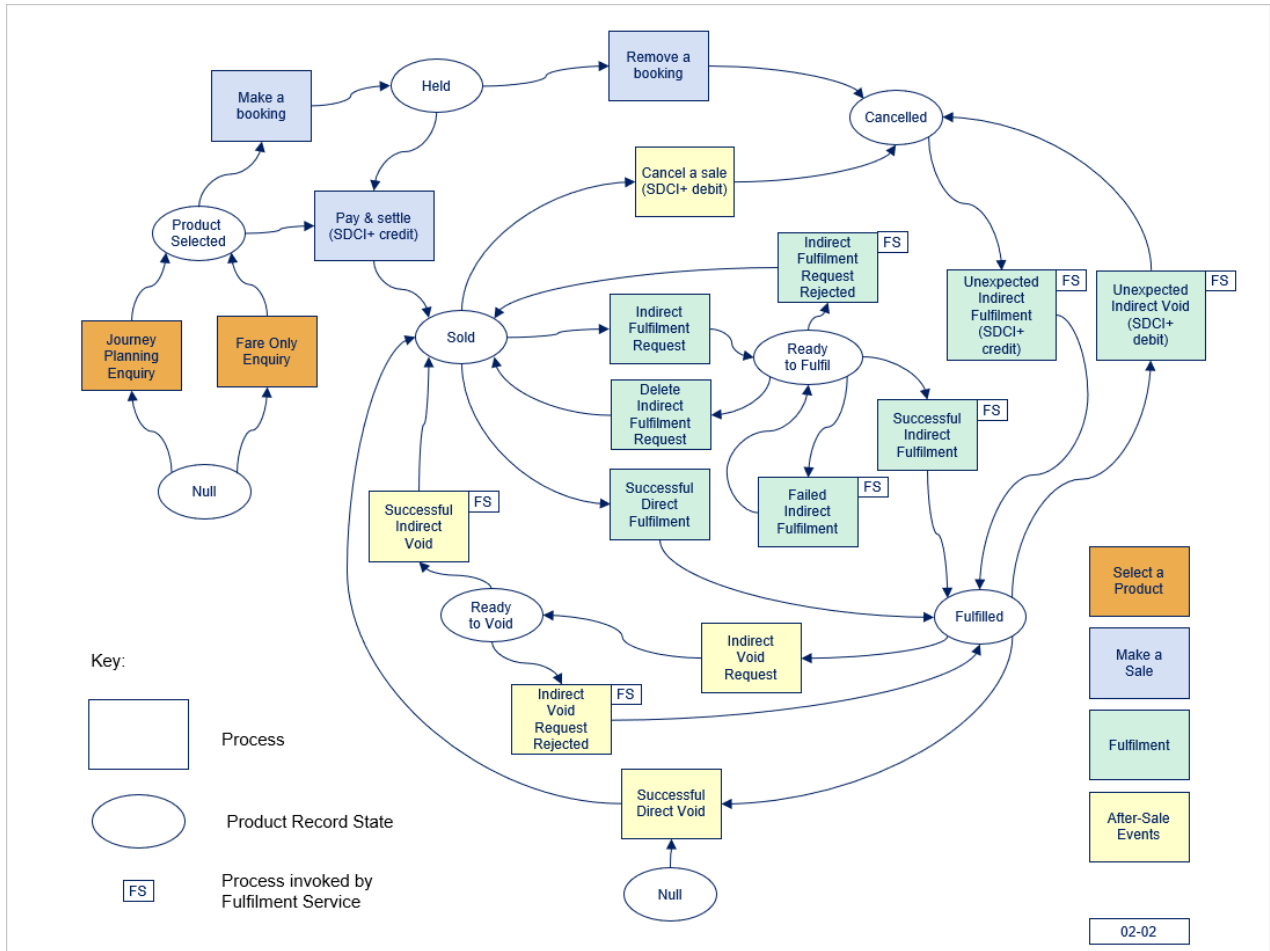

Appendix C. Accreditation process checklist

Stage of Accreditation Process	Item
Initial Discussion	System Proposal provided to RDG Accreditation.
	Access to RDG documentation through ASSIST.
	ASSIST training completed.
Application	Functional Specification document issued.
	Application for accreditation in ASSIST.
Scheduling Accreditation	Accreditation estimate provided.
	Accreditation scheduled.
TIS Development	Connectivity to (as required): <ul style="list-style-type: none"> • Journey Planner. • ALTS/Lennon. • Test/Live LSM. • Test/Live TMS/other Fulfilment Service. • Test/Live Reservation Service. • Approved data feeds. • An eTVD.
	Access to verification tools (if new TIS): <ul style="list-style-type: none"> • Test LSM Console. • Test Reservation Service portal. • Test TMS portal.
	Internal testing completed.
	Forms <ul style="list-style-type: none"> • Lennon Machine Type, if writing SDCl+.
	Third-party certification, such as ITSO or Oyster.
Compliance Review	Compliance Review document issued.

Accreditation Testing	Connected to (as required):
	<ul style="list-style-type: none"> • ALTS • Test LSM • Test TMS/other Fulfilment Service • Test Reservation Service • Approved data feeds • An eTVD
	TIS version captured in (as required):
	<ul style="list-style-type: none"> • SDCI+ 2C record • LSM CTRs
	Test fulfilment indicators (as required):
	<ul style="list-style-type: none"> • Specimen CCST stock • Specimen PRT stock • Test barcode key • Test mTicket colour scheme • Test eTicket colour scheme • Test sTicket colour scheme • Test ITSO keys
	Accreditation testing completed.
	No open Cat-1 RDG JIRA issues.
Pilot	Retail licence issued to sponsoring retailer.
	Connected to (as required):
	<ul style="list-style-type: none"> • Lennon • Live LSM • Live TMS/other Fulfilment Service • Live Reservation Service • Approved data feeds • An eTVD
	TIS version captured in (as required):
	<ul style="list-style-type: none"> • SDCI+ 2C record • LSM CTRs
	Distribution of live barcode key (lead time necessary).
	No open Cat-1 or Cat-2 RDG JIRA issues.
	Authorisation of wider deployment of system version.
Certification	Conditions of Approval document issued.
	Certificate of Accreditation issued.